

[H]

HANDLE

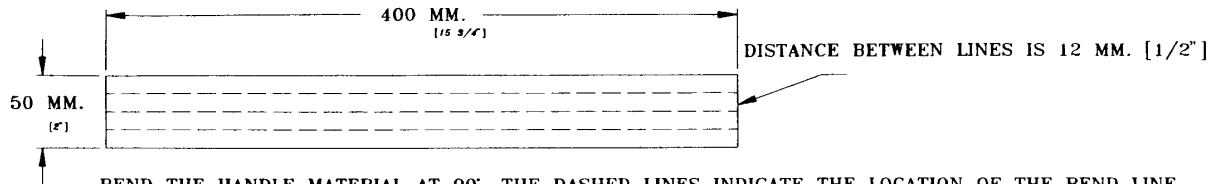

BEND THE HANDLE MATERIAL AT 90°. THE DASHED LINES INDICATE THE LOCATION OF THE BEND LINE.
TO BEND METAL IS TO FOLD IT USING A MACHINE CALLED A BRAKE.

COMPLETED TRAY

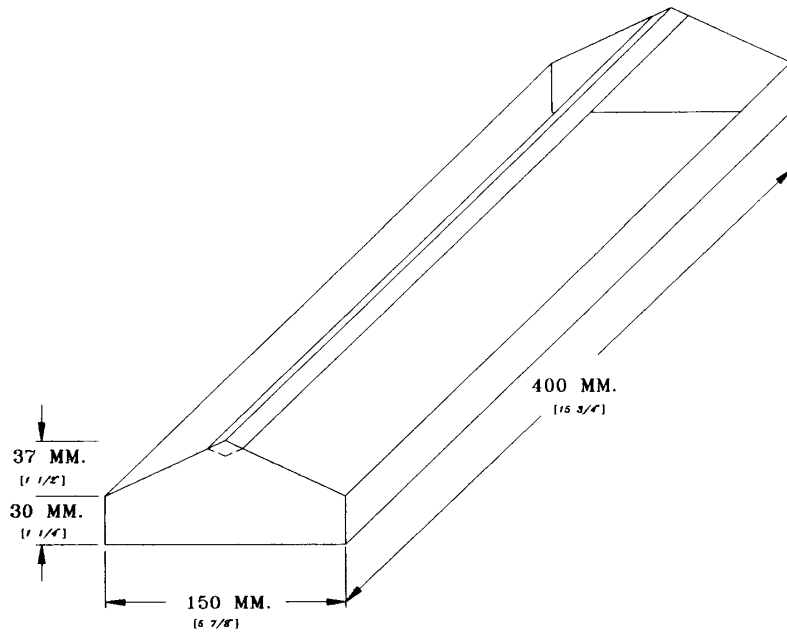

EVALUATION	PROJ. SHT: / 10	WELD QUAL.: / 50	APPEARANCE: / 30	FINISH: / 10	MK:
NAME:	START DATE:	COMPLETION DATE:	HOURS:		

